

AGF

B R O M E

INSTRUCTIONS ASSEMBLAGE

Version 1.0



POSTE DE TRAVAIL

Instructions Assemblage Poste de Travail

- Boulon les cabinets de bas ensemble—prendre vis 5/16 x 3/4 long et contre-écrou 5/16
- Ajuster niveau avec les patins niveleurs
- Vis les dessus sur les cabinet par l'intérieur des cabinets avec vis de bois #14 - 1 1/4 long
- Vis les coup pied a les cabinets avec vis auto taraudeuses #8 - 3/4
- Pour installation des Poteau de haut ; commence avec installation de la première Poteau—flush sur la bord .Avec un dessus en Inox—il faut pré-percer. Prendre le trou dans le milieu de Poteau comme guide. (excepté si trou c'aligne avec le joint dans le dessus) .Prendre vis de bois #14 - 1 1/4 .
- Vis bracket en dessus de le top avec vis de bois #14 - 1 1/4
- Vis auto taraudeuses #14-1" dans Poteau et cote de la table
- Répéter pour chaque Poteau nécessaire.
- Commence a installer les panneau arrière quand tous les Poteau sont installer.
- Installer les Cabinets de haut quand tous les panneau arriéré soit installer.
- Vis les cabinets ensemble avec vis auto taraudeuses #8 - 3/4" long
- SVP –Voir les pages suivant pour assistance



B R O M E

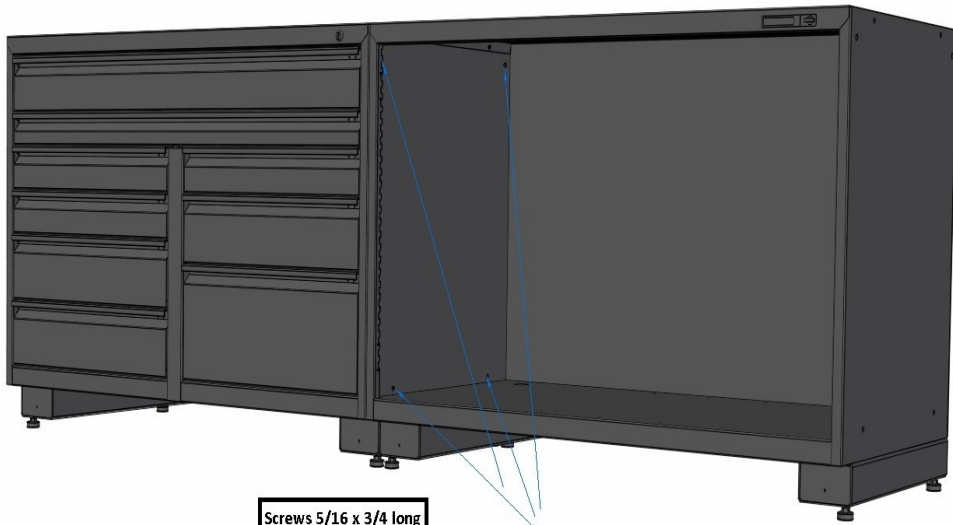

Screws 5/16 x 3/4 long
Lock nuts 5/16

BOLT CABINETS TOGETHER

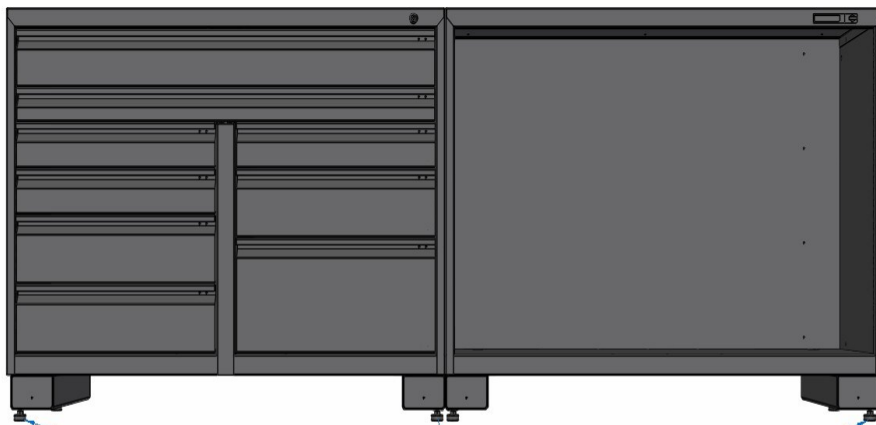

AJUST LEVEL WITH LEG'S



B R O M E

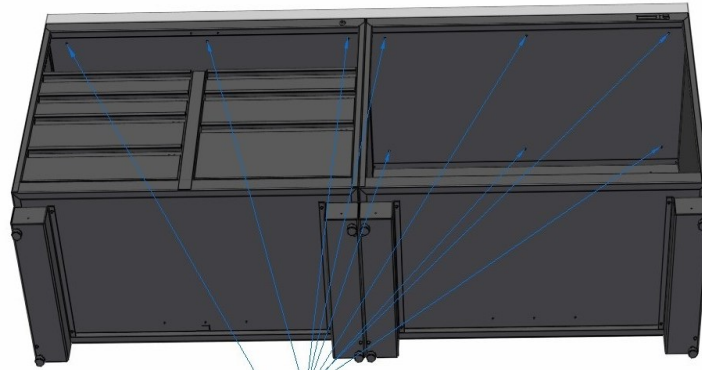

SCREW TOP Wood screws #14 - 1 1/4 long

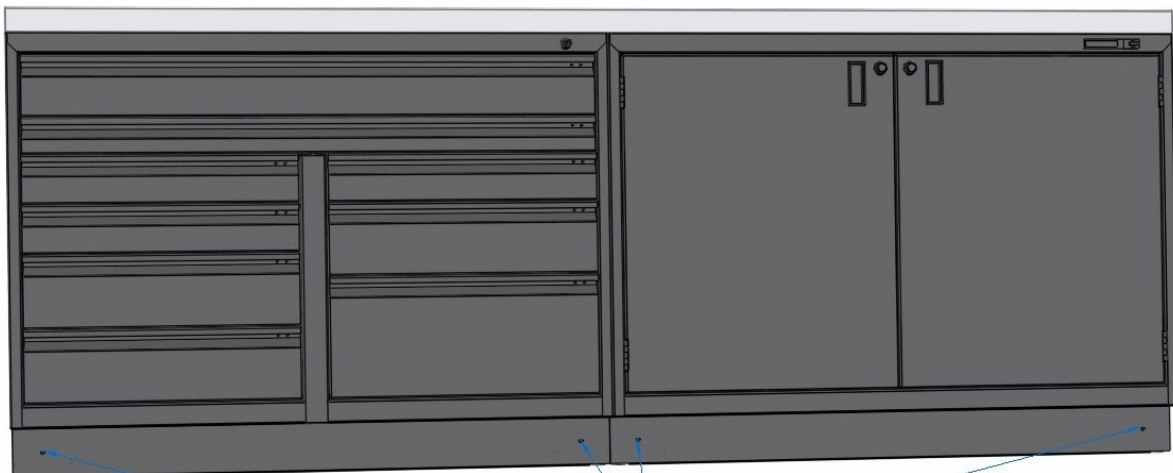

SCREW KICK PLATE Self tapping screws #8 - 3/4



B R O M E

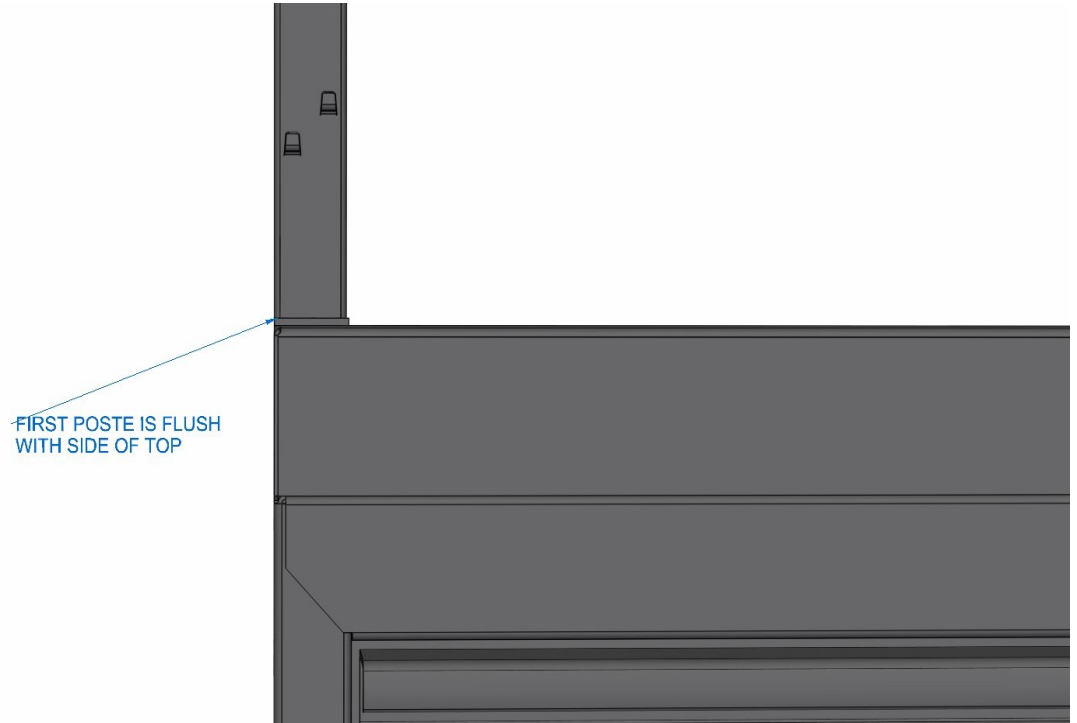

FIRST POSTE IS FLUSH WITH SIDE OF TOP

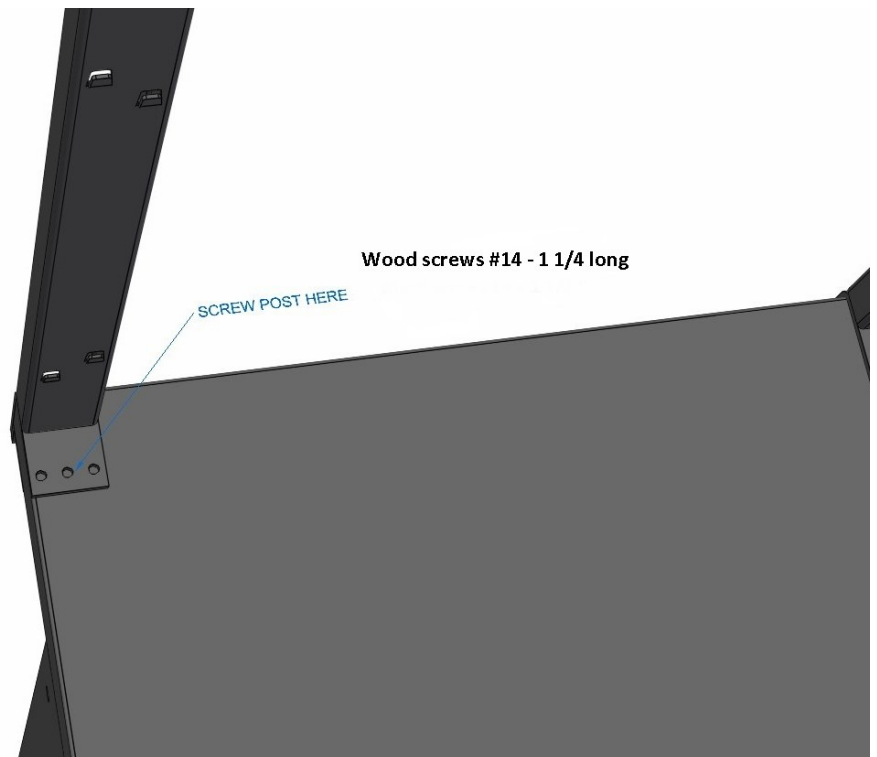

Wood screws #14 - 1 1/4 long

SCREW POST HERE



B R O M E

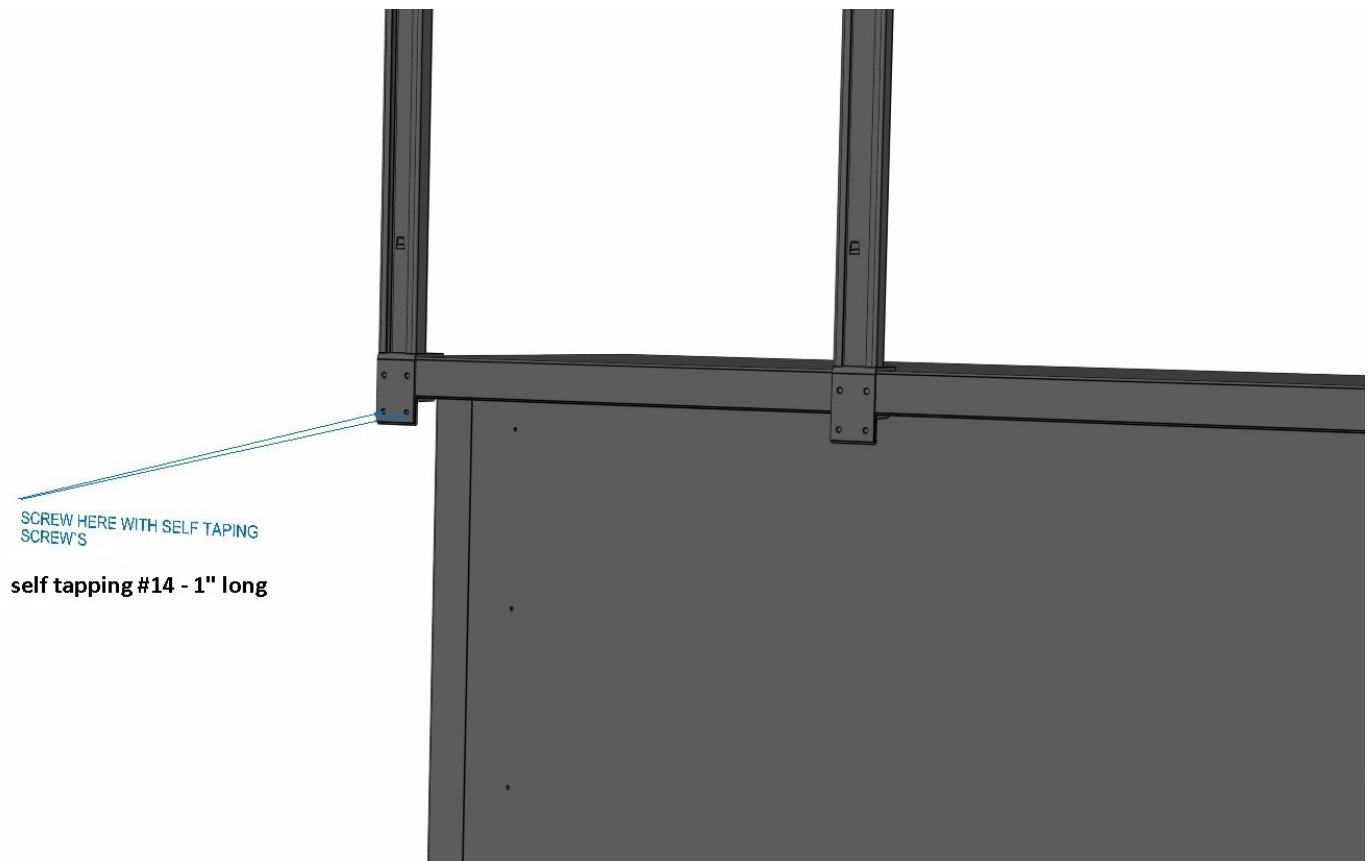
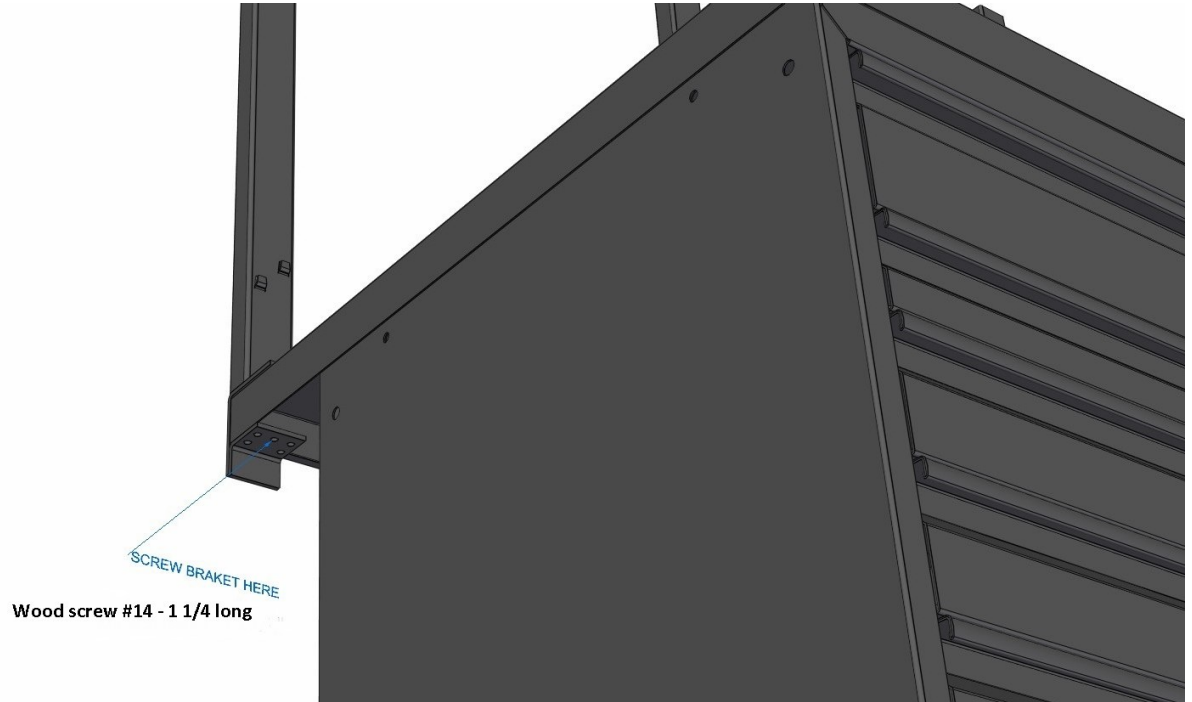



B R O M E

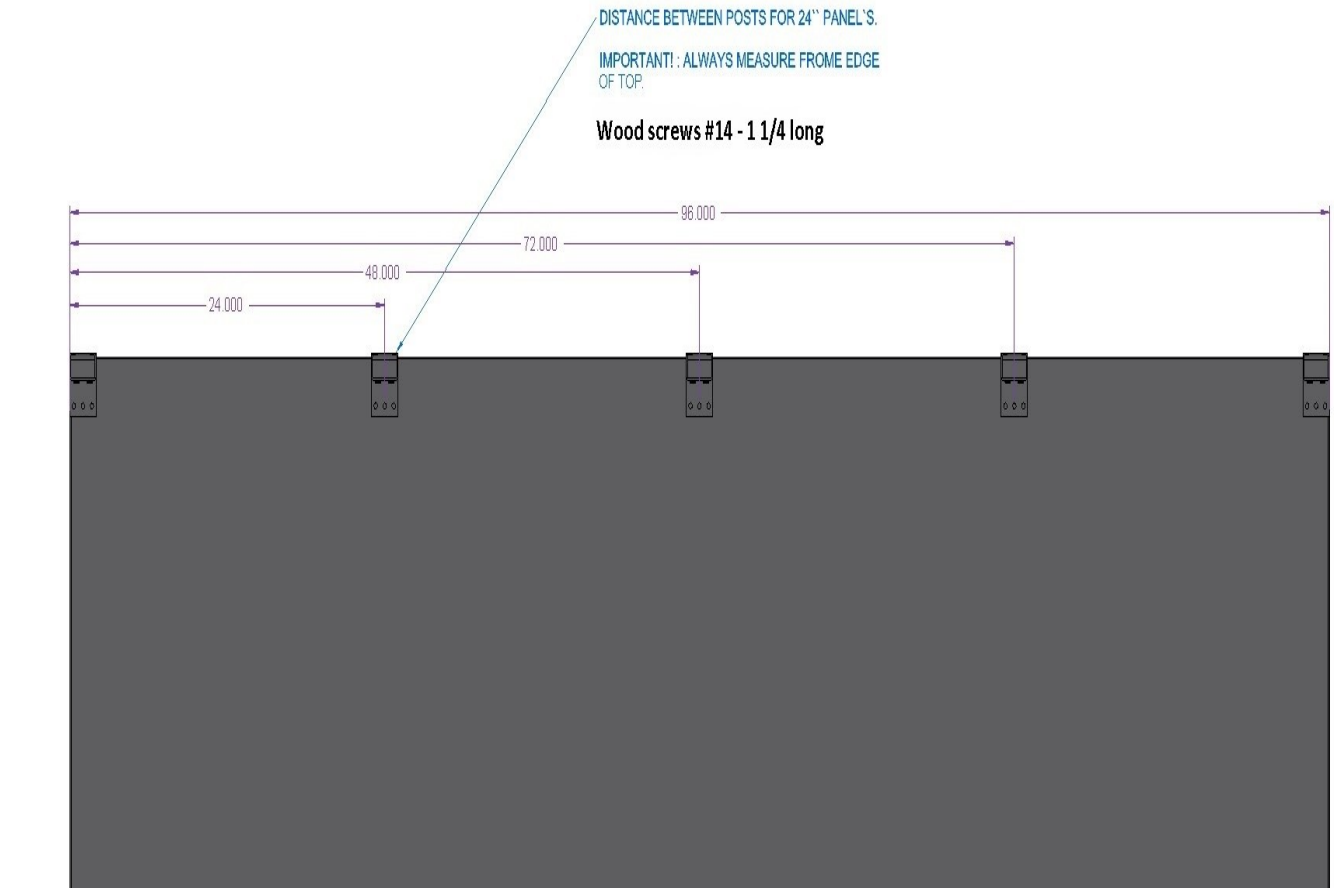
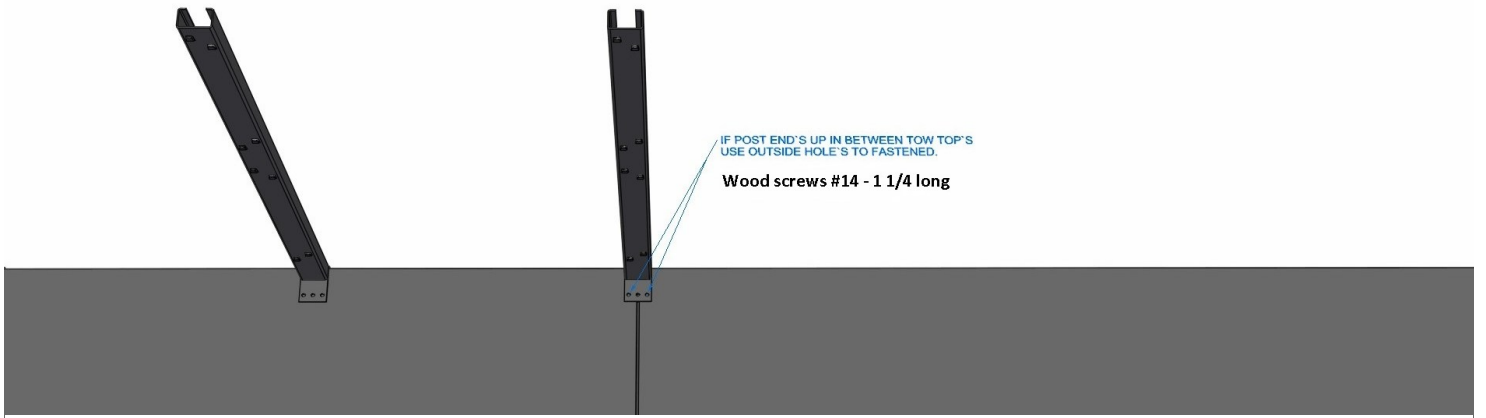



B R O M E

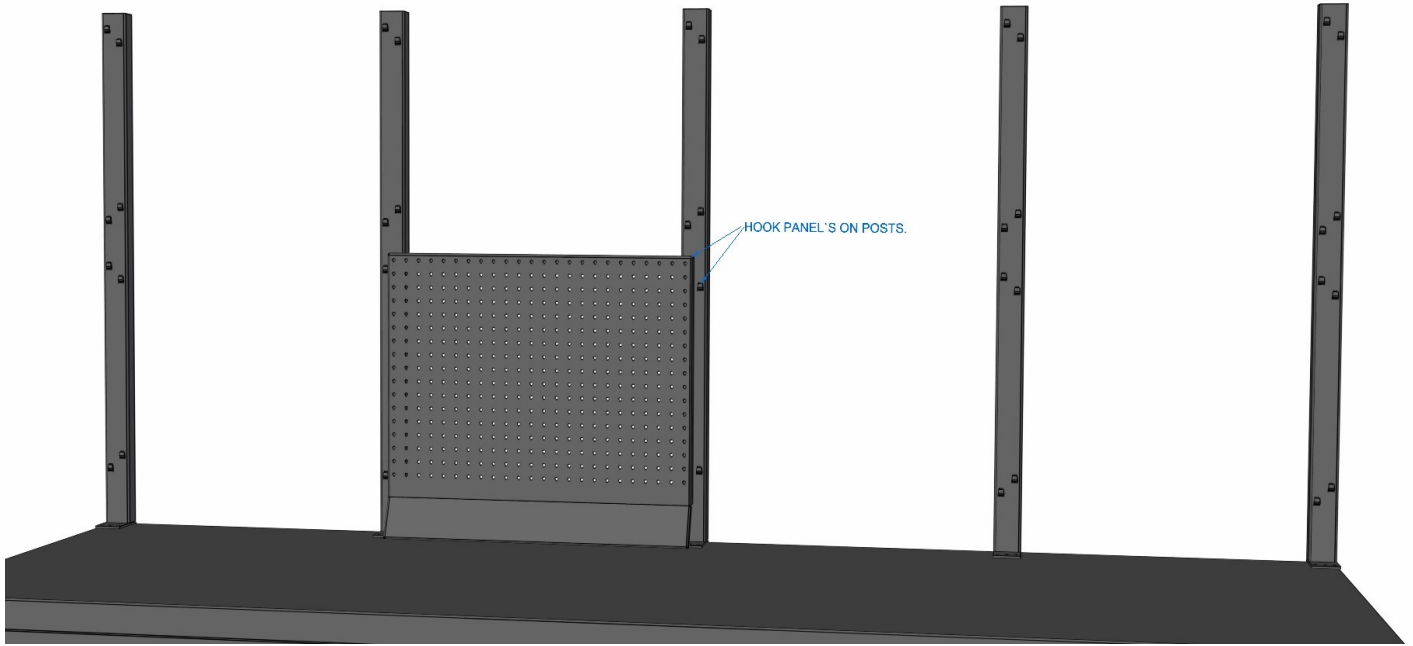

HOOK PANEL'S ON POSTS.

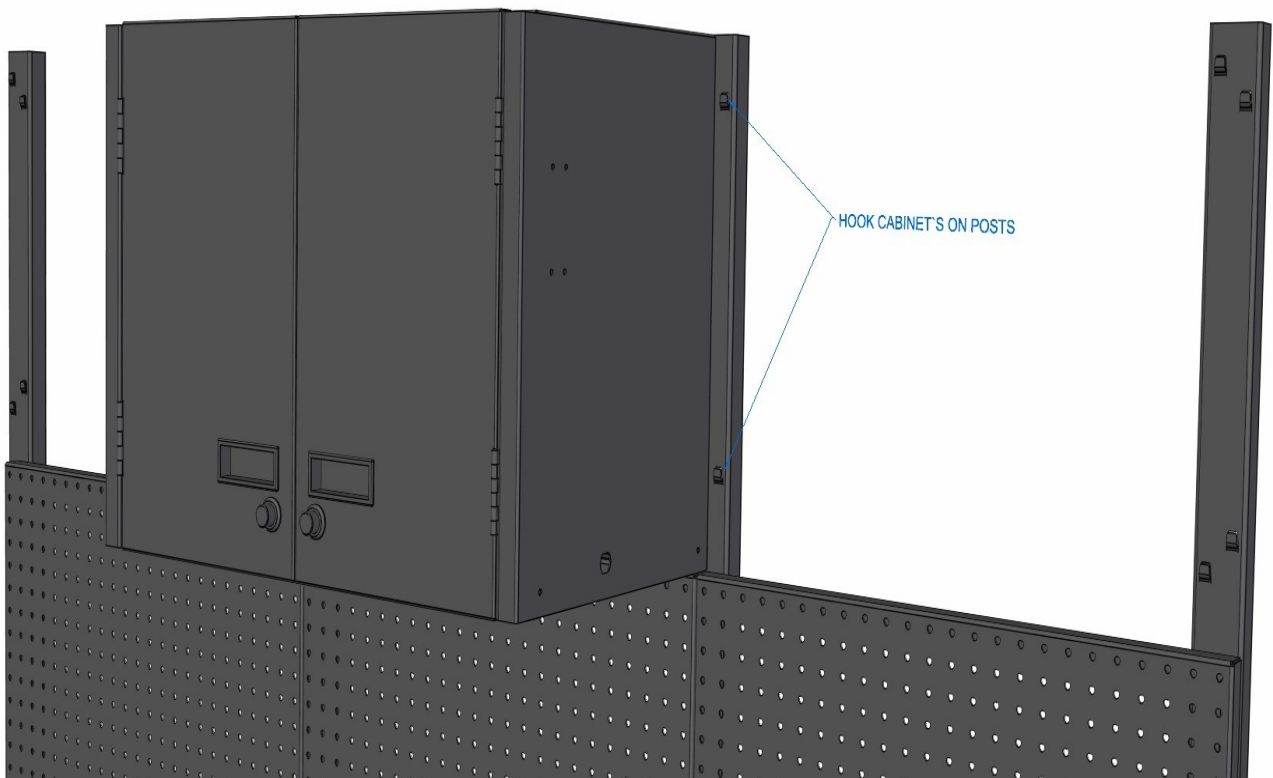

HOOK CABINET'S ON POSTS



B R O M E

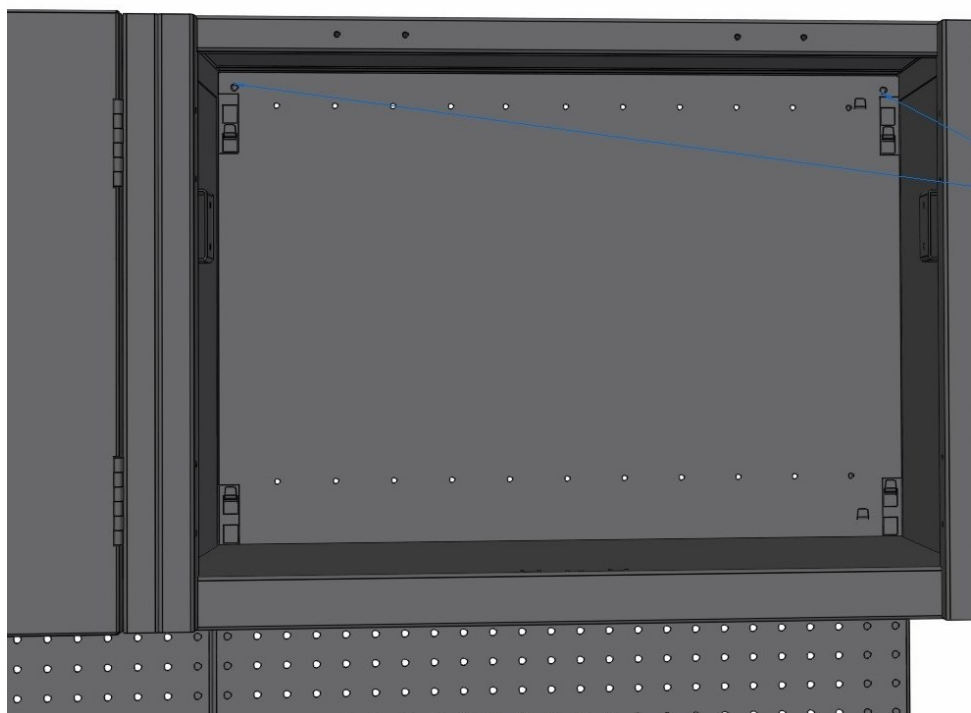
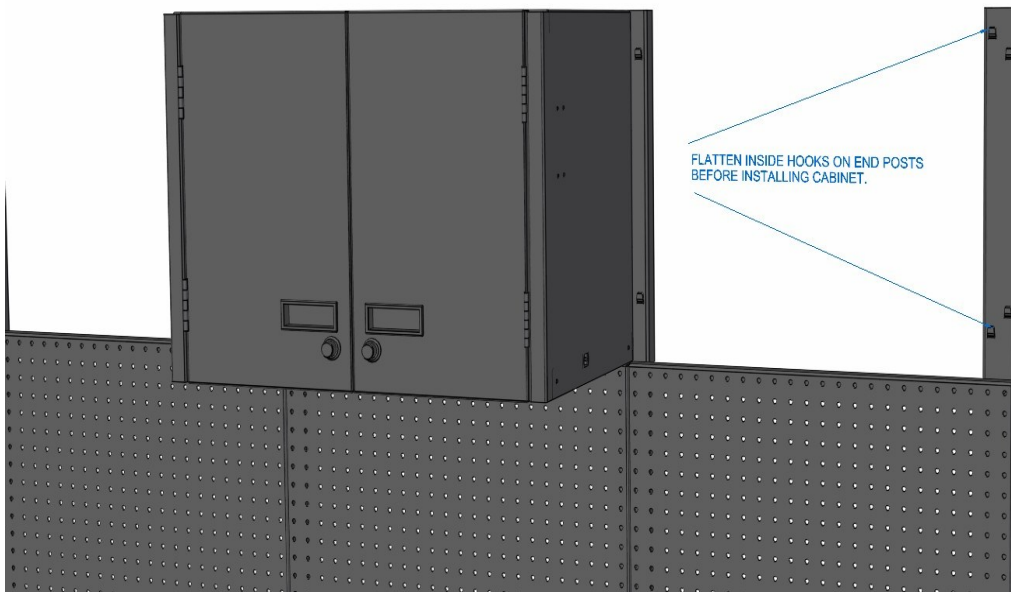

SCREW CABINET WITH SELF TAPING SCREWS.

Self tapping Screw #8 - 3/4" long



B R O M E

